

ELECTRAVIA® designs, develops, manufactures and markets global electrical propulsion systems to equip ultralights, motorgliders, UAV and light aircraft. ELECTRAVIA® masters electronics for controllers and batteries management, propellers design, and has finalized partnerships with motors and batteries manufacturers. The engineering department of the company may implement dedicated solutions for each aircraft.

## DATA SHEET

E-MOTOR GMPE 201 : DC brushed motor

This engine can be used to replace any two strokes engines up to 43 HP

Mass without belt reduction gear : 12 kg (26.7 lb)

Mass with belt reduction gear and propeller flange : 16 kg (35.5 lb)

<i>Technical data</i>	<b>power</b>	<b>efficiency</b>	<b>torque @ motor shaft</b>	<b>current</b>
Peak power (30 s)	32 kW (43 HP)	91%	55 Nm	275 A
Max power (10 mn)	26 kW (35 HP)	92%	45 Nm	225 A
Max continuous	20 kW (27 HP)	93%	35 Nm	175 A

Temperature @ brush holder level :

Normal operating range (green zone) : -10°C to 70°C

Emergency operating range (red zone) : 70°C to 90°C

Max temperature : 90°C (194 °F)

Speed : 47 RPM/V @ 4 A and 42 RPM/V @ 300 A

Max motor speed : 6000 RPM

Propeller direction : either clockwise or counter-clockwise

→ ELECTRAVIA® recommends E-PROPS® propellers to get the best propulsion efficiency and the best noiseless performances



CONTROLLER FOR GMPE 201 : DC/DC Converter

Mass : 2.7 kg (6 lb)

Efficiency : 99 %

Max current : 300 A

Max Voltage : 136 V

Power control by potentiometer (0-5 kΩ) or Hall sensor (0-5 V)



## GMPE 201 – DIMENSIONS

8 holes tapped M6x1.0  
on 194mm PCD



4 holes tapped M8x1.25  
on 60mm PCD

Shaft - 19mm diameter x 40mm long  
with ISO keyway & centre  
hole tapped M8x1.25

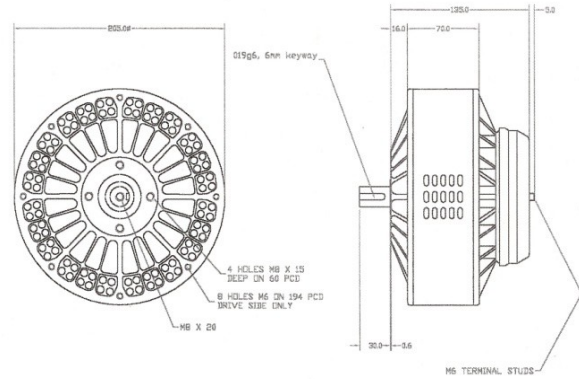

SIZE: 210 mm diameter x 200 mm length  
(from propeller interface to rear motor face)

## GMPE 201 - PERFORMANCES @ 126V

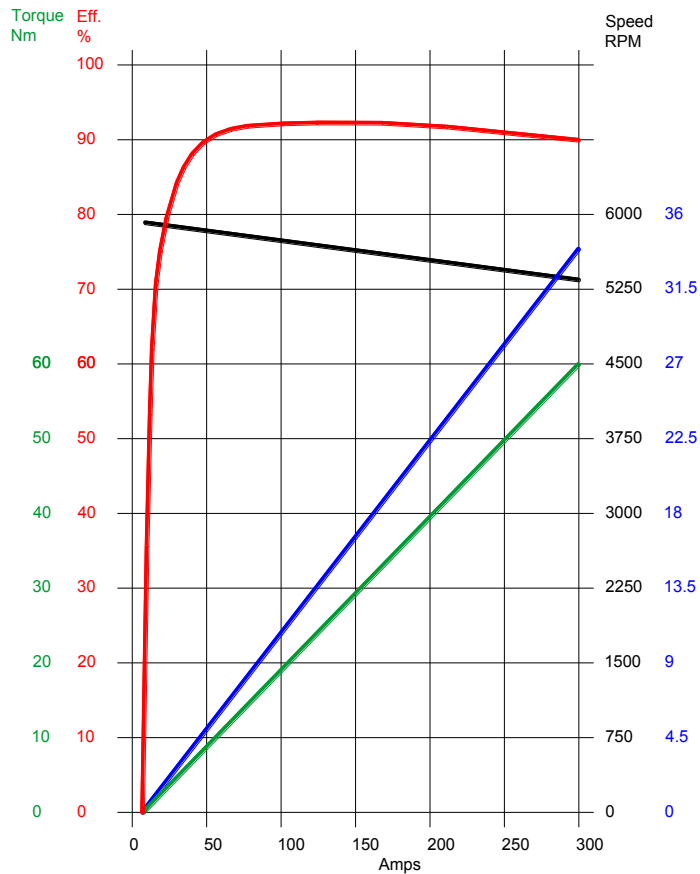

### ▲ WARNING

**Electrical engine E-MOTOR GMPE 201 is not a certificated aircraft engine.** It has not received any safety or durability testing, and conforms to no aircraft standards. It is for use in experimental, uncertificated aircraft, ultralights motorgliders, paramotors, and any vehicles only in which an engine failure will not compromise safety.

User assumes all risk of use, and acknowledges by his use that he knows this engine is subject to sudden stoppage.

Never fly an aircraft equipped with this engine in circumstances or in areas, in weather conditions or in altitudes where you have no chance for successful landing after an engine failure.

Read very attentively the Operator's Manual before starting the electrical engine. Failure to do so may result in personal injuries including death.

ELECTRAVIA® reserves the right at any time to discontinue or change specifications, designs, features, models or equipment without incurring obligation.

For more information, please contact us:

**[www.electravia.fr](http://www.electravia.fr)**  
**[infos@electravia.fr](mailto:infos@electravia.fr) / +33(0)4 92 57 99 40**